

Orientalmotor

RoHS RoHS-Compliant

Universal Controller

SCX11

Equipped with program editing and execution functions, the highly-functional and sophisticated **SCX11** controller is now available. Use the **SCX11** as a stored program controller to connect to any of Oriental Motor's standard pulse input drivers. The **SCX11** is also able to control the motor via various serial ports such as USB, RS-232C and **CANopen**.



Features

● 100 Sequence Programs can be Stored

The **SCX11** can store up to 100 programs and execute various operations, from simple movements like "repeated positioning operation" to complicated controls like "operation by calculating the value based on external inputs".

● Easy Operation

The convenient and easy-to-use PC software, "Immediate Motion Creator for **CM/SCX** Series", is provided with the **SCX11**. Easily start an operation with the click of a button or start key by setting the travel amount and speed. The GUI allows for easy program creation by selecting commands from the command list. Other functions available include, real time monitor for the teaching position, current position and I/O status, system parameter setting and I/O assignment.



PC software "Immediate Motion Creator for **CM/SCX** Series" (Included)

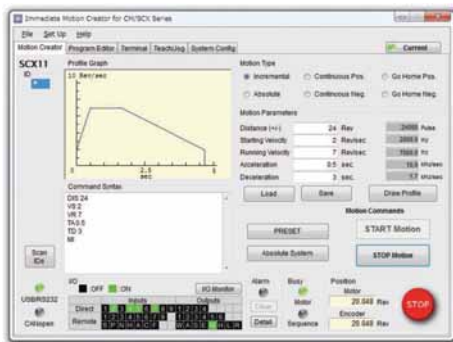

● USB Port as Standard Equipment

The **SCX11** has a mini USB port on the front panel which can directly connect to a PC through a commercially available mini USB cable. No special cable or converter is required.

● Changeover from SCX10 Possible

Functions like serial communication, I/O signals, commands etc. are the same like **SCX10**, a changeover is easy.

● Intelligent Setting

Program data for speed and travel amounts by setting the "User Unit" parameter. Data can be programmed in units such as "mm", "inch" and "revolution".

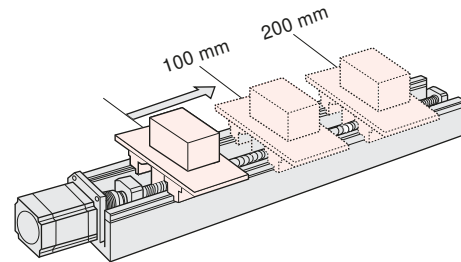

● External Encoder Input

The **SCX11** has a function for external encoder inputs which enables continuous monitoring of the feedback position and position error. Line driver, open collector and TTL inputs are compatible.

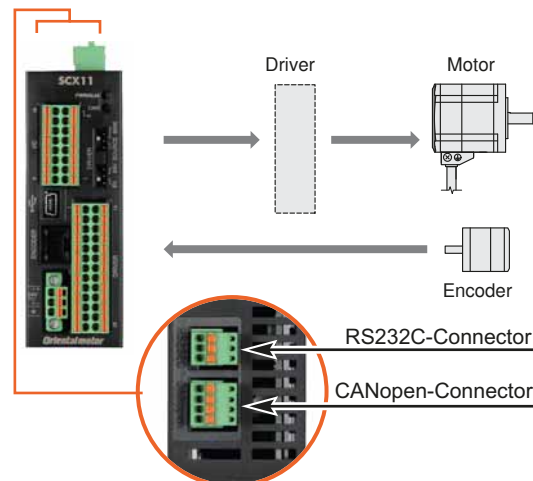

● Various Interfaces for Operation

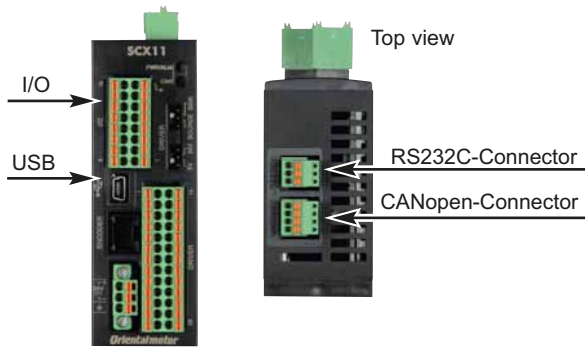

◇ Stand-Alone Operation Using Sensors and Switches
 The **SCX11** can operate as a stand-alone controller, without a PC or programmable controller by utilizing 9 general inputs and 4 general outputs to select the desired sequences.

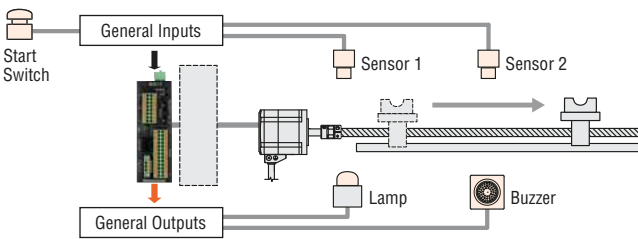

◇ Direct Command Operation via CANopen
 The **SCX11** has a standard built-in interface for CANopen.
 * CANopen for the **SCX11** is certified by CiA (CAN in Automation).

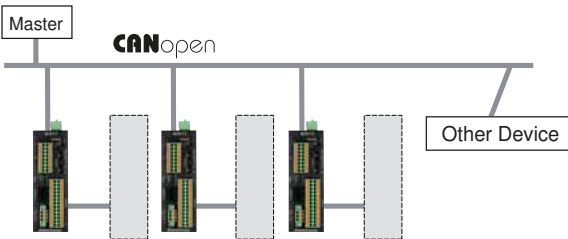

◇ Operation Using a PC
 The **SCX11** can connect to a PC via RS-232C or USB*. The **SCX11** can also be connected via an RS-232C daisy chain connection for multi-axis control with another **SCX11** or other products such as the ASX Series all-in-one closed loop α STEP motor or **SCX10**.

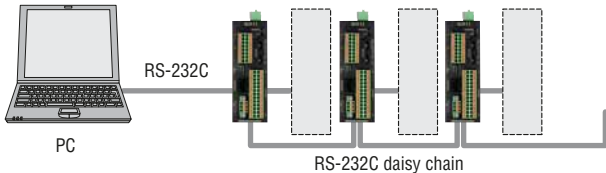

* Multi-axis control via USB is configured with multiple USB ports.

◇ Operation Using a Programmable Controller
 The **SCX11** can communicate a wide variety of signals via I/O to a programmable controller. Serial communications is also available, if the programmable controller has a USB or RS-232C interface built-in.

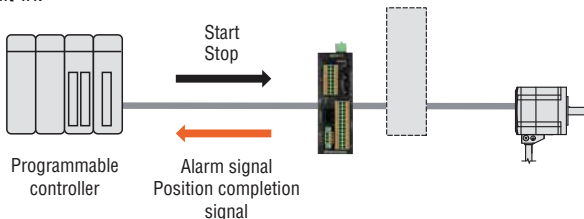

● Two Types of Operations

◇ Executing Sequence Operation [Stored Program Function]
 This function is available for conditional branching using general-purpose I/O, wait processes using internal timers and other operations based on sequence control including setting the positioning and speed data. The **SCX11** can store up to 100 different programs that can be selected and executed via USB, RS-232C, CANopen and I/O port.

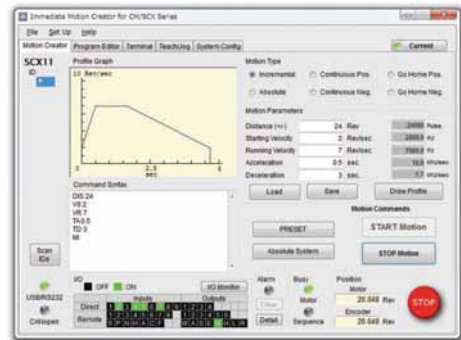

[Example program]

```
Seq 1
[1] VS 1 ; Starting Velocity*
[2] VR 9 ; Running Velocity*
[3] TA 1 ; Acceleration Time
[4] TD 2 ; Deceleration Time
[5] DIS 2 ; Incremental Motion Distance*
[6] LOOP 3 ; Begin Counted LOOP Block
[7] MI ; Move Incremental Distance
[8] MEND ; Wait for Motion End
[9] WAIT 1 ; Wait for Specified Time
[10] ENDL ; End of LOOP Block
[11] MA O ; Move to Absolute Position
[12] MEND ; Wait for Motion End
[13] END ; End Sequence
```

* Set the speed and travel amount as the unit of your actual motion such as "mm", "inch" and "revolution".

◇ Direct Command Operation

Operate a motor directly by sending commands via the serial port (USB, RS-232C, CANopen) from a PC or programmable controller. This function is suitable for applications where positioning data is updated frequently or managed all at once by the PC or programmable controller.

```
>DIS=60
DIS=60 mm
>VR=5
VR=5 mm/sec.
>VS=1
VS=1 mm/sec.
>TA=0.5
TA=0.5
>TD=0.5
TD=0.5
>MI
>
```

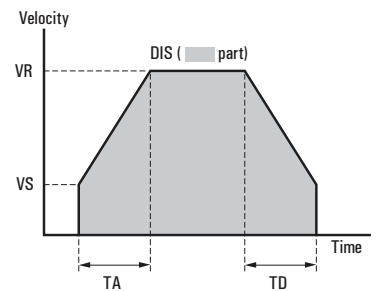

[Example Commands]

- DIS ; Incremental Motion Distance
- VR ; Running Velocity
- VS ; Starting Velocity
- TA ; Acceleration Time
- TD ; Deceleration Time
- MI ; Move Incremental Distance
- MA ; Move to Absolute Position
- MC P ; Move Continuously, Positive
- MC N ; Move Continuously, Negative
- M G H P ; Seek Mechanical Home Position
- AL M C L R ; Clear Alarm Condition

Specifications

Model		SCX11
Operation Mode		Immediate command / Stored program
Sequence Programs	Number of sequence programs	Max.100
	Program size	6kB Maximum for total compiled sequences 6kB Maximum for 1 sequence (text data)
	Programming Method	Immediate Motion Creator for CM/SCX Series [supplied software] or General terminal software
	Function Example	Subroutines, Math/Logical operators, User variables
Control	Number of Control axis	Single axis
	Control Modes	Positioning operation (INDEX operation) Return to mechanical home operation (HOME operation) Continuous operation (SCAN operation) 1-pulse Operation (JOG operation)
	Operating mode	Incremental / Absolute
	Starting Velocity	0~1.24MHz (1Hz increments)
	Speed range	1Hz~1.24MHz (1Hz increments)
	Acceleration time	0.001~500sec (0.001 sec increments)
	Position range	-2,147,483,648 to +2,147,483,647 pulses maximum
	Mode for mechanical home seeking	3 sensor mode, 2 sensor mode, 1 sensor mode (+LS, -LS, Home, Sensor, Timing) Sensor-less Mode (for ESMC Controller)
	Features	User Unit, Teaching Positions, Linked Motion, Multi Axis Operation, External encoder input, Protective Functions
Driver Interface	Pulse Output	1 Pulse Mode/2 Pulse Mode <u>Line Driver Output (Line receiver input /Photo-coupler input compatible)</u>
	Input	5 Signals Photo-coupler input Input voltage 4.25 - 26.4V, Input resistance 3kΩ Built-in 5 V/24 VDC power supply Sink logic/Source logic compatible
	Output	8 signals Photo-coupler open-collector outputs DC30V 20mA or less Built-in 5V/24VDC power supply Sink logic/Source logic compatible
	Encoder Input	A-phase, B-phase, Index Max. Frequency 1MHz A-phase, B-phase, Index Max. Frequency 1MHz Line-driver, Open collector and TTL compatible Built-in 5VDC power supply
External Encoder Input		A-phase, B-phase, Index Max. Frequency 1MHz Line-driver, Open collector and TTL compatible Built-in 5VDC power supply
I/O	Input	9 signals (configurable) Photo-coupler inputs Input voltage 4.25-26.4V Input resistance 5.4kΩ
	Output	4 signals (Configurable) Photo-coupler open-collector outputs DC30V 20mA or less
Serial Communications	USB	USB2.0 compatible (Virtual COM port) Mini USB terminal 9600, 19200, 38400, 57600, 115200 bps (9600 is default.)
	RS - 232C	Start-stop synchronous method, NRZ (Non-Return Zero), full-duplex 8 bits, 1 stop bit, no parity 9600, 19200, 38400, 57600, 115200 bps (9600 is default.) Daisy-Chain compatible (up to 36 axis)
	CANopen	CiA 301 Ver4.02 compliant 10kbps, 20kbps, 50kbps, 125kbps, 250kbps, 500kbps, 800kbps, 1Mbps
Power Input	Voltage	24 VDC ±10%
	Current	0.26 A
Mass		0.18 kg
Environmental Condition	Ambient Temperature	0 - 50°C (non-freezing)
	Ambient Humidity	20 - 85 % (non-condensing)

● When using the **SCX11** with either the **CSK** Series or **UMK** Series 2-phase motor driver packages, the **SCX11** and the driver need to be set to "2-Pulse input mode", CW and CCW pulse input.

Dimensions (Unit = mm)

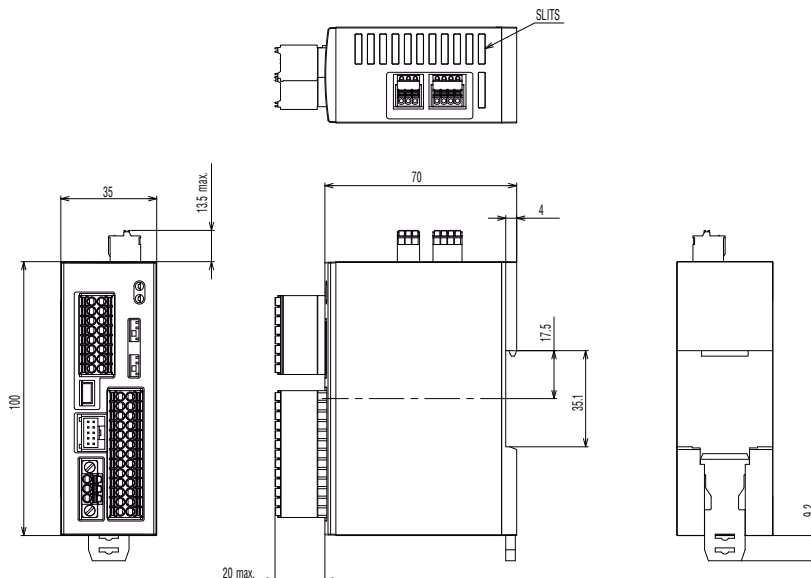

For more information, please read the "Operating Manual" for the use of this product, or please contact the nearest Oriental Motor sales office.

Orientalmotor

This product is manufactured at a plant certified with the international standards **ISO 9001** (for quality assurance) and **ISO 14001** (for systems of environmental management).

Specifications are subject to change without notice.
This catalogue was published in March, 2015.

ORIENTAL MOTOR (EUROPA) GmbH

www.orientalmotor.de

European Headquarters

Schießstraße 74

40549 Düsseldorf, Germany

Tel: 0211-5206700 Fax: 0211-52067099



Other countries:

www.orientalmotor.eu



ORIENTAL MOTOR (UK) LTD.

www.oriental-motor.co.uk

UK Headquarters

Unit 5, Faraday Office Park,

Rankine Road, Basingstoke,

Hampshire RG24 8AH, U.K.

Tel: 01256-347090 Fax: 01256-347099



ORIENTAL MOTOR (FRANCE) SARL

www.orientalmotor.fr

France Headquarters

56, Rue des Hautes Pâtures

92000 Nanterre Cedex, France

Tel: 01 47 86 97 50 Fax: 01 47 82 45 16



ORIENTAL MOTOR ITALIA s.r.l.

www.orientalmotor.it

Italy Headquarters

Via A. De Gasperi, 85

20017 Mazzo di Rho (MI), Italy

Tel: 02-93906346 Fax: 02-93906348



ORIENTAL MOTOR CO., LTD.

www.orientalmotor.co.jp

Headquarters

4-8-1 Higashiueno

Taito-ku, Tokyo 110-8536, Japan

Tel: (03)6744-0361 Fax: (03)5826-2576

Customer Center (Support in German & English)

00800 - 22 55 66 22*
CALL OM CC

Mo-Do: 08:00 - 17:30 MEZ Freitag: 08:00 - 16:00 MEZ

* Free Call Europe

info@orientalmotor.de

For more information please contact: