

## Motor Selection

### Leadscrew Application

#### Requirements

- Move Distance  mm
- Time to Make Move  s
- Maximum Linear Speed  mm/s
- Push/Pull Force  N

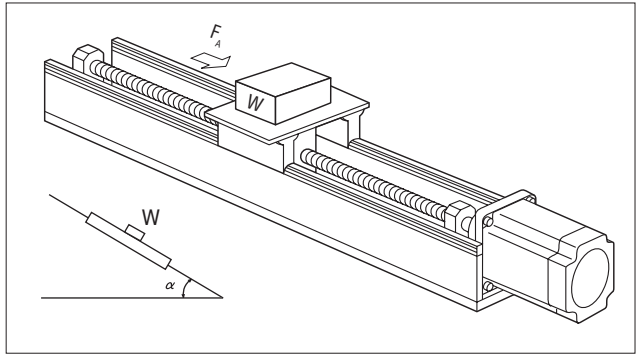

- Stopping Accuracy  mm
- Work + Table Weight  kg
- Angle  °
- Distance per Pulse  mm
- Stop Time  s
- Screw Diameter  mm
- Screw Length  mm
- Screw Pitch  mm/rev
- Screw Efficiency  %

#### Additional Information

---

---

---

---

---

#### Alternate Motion Profile

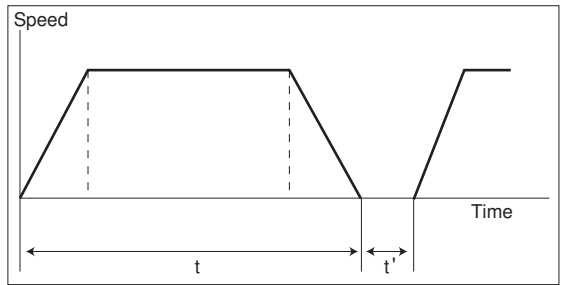

#### Customer Information

Date: \_\_\_\_\_

Company: _____	Application: _____
Name: _____	_____
Address: _____	_____
_____	_____
Tel: _____	_____
Fax: _____	_____

#### Contact:

U.K.	Oriental Motor (UK) LTD	Tel: <b>01256-347090</b>	Fax: <b>01256-347099</b>
France	Oriental Motor (France) SARL	Tel: <b>01 47 86 97 50</b>	Fax: <b>01 47 82 45 16</b>
Italy	Oriental Motor Italia s.r.l.	Tel: <b>02-9390 6346</b>	Fax: <b>02-9390 6348</b>
Germany & All other countries	Oriental Motor (Europa) GmbH	Tel: <b>+49-211-52067-00</b>	Fax: <b>+49-211-52067-09</b>