

Motor Selection

■ Belt and Pulley Application

■ Requirements

| | | | | | |
|------------------------|--|-----------------------------------|-----------------------|--|---------------------------------|
| ▪ Move Distance | <input type="text" value="l:"/> | <input type="text" value="mm"/> | ▪ Stopping Accuracy | <input type="text" value="+/- :"/> | <input type="text" value="mm"/> |
| ▪ Time to Make Move | <input type="text" value="t:"/> | <input type="text" value="s"/> | ▪ Work + Table Weight | <input type="text" value="m :"/> | <input type="text" value="kg"/> |
| ▪ Maximum Linear Speed | <input type="text" value="v:"/> | <input type="text" value="mm/s"/> | ▪ Angle | <input type="text" value="α :"/> | <input type="text" value="°"/> |
| ▪ Push/Pull Force | <input type="text" value="F<sub>(+/-)</sub> :"/> | <input type="text" value="N"/> | ▪ Distance per Pulse | <input type="text" value="Δl :"/> | <input type="text" value="mm"/> |
| | | | ▪ Stop Time | <input type="text" value="t' :"/> | <input type="text" value="s"/> |
| | | | ▪ Pulley Diameter | <input type="text" value="D<sub>p</sub> :"/> | <input type="text" value="mm"/> |
| | | | ▪ Pulley Weight | <input type="text" value="m<sub>p</sub> :"/> | <input type="text" value="kg"/> |
| | | | ▪ Pulley Width | <input type="text" value="b<sub>p</sub> :"/> | <input type="text" value="mm"/> |
| | | | ▪ Pulley Material | <input type="text" value="p<sub>p</sub> :"/> | <input type="text" value=""/> |

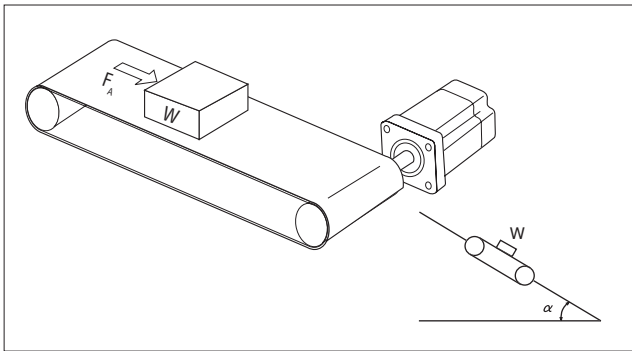

Additional Information

■ Alternate Motion Profile

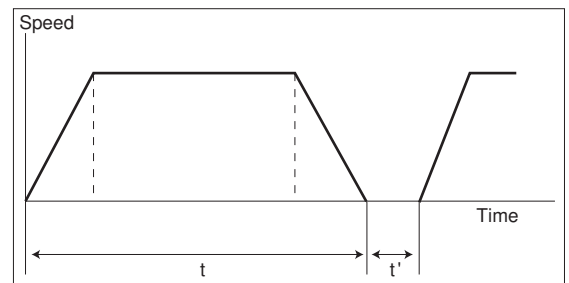

■ Customer Information

| | |
|-------------------------------|-----------------------------------|
| Company: <input type="text"/> | Date: <input type="text"/> |
| Name: <input type="text"/> | Application: <input type="text"/> |
| Address: <input type="text"/> | <input type="text"/> |
| <input type="text"/> | <input type="text"/> |
| Tel: <input type="text"/> | <input type="text"/> |
| Fax: <input type="text"/> | <input type="text"/> |

■ Contact:

| | | | |
|-------------------------------|------------------------------|------------------------------|------------------------------|
| U.K. | Oriental Motor (UK) LTD | Tel: 01256-347090 | Fax: 01256-347099 |
| France | Oriental Motor (France) SARL | Tel: 01 47 86 97 50 | Fax: 01 47 82 45 16 |
| Italy | Oriental Motor Italia s.r.l. | Tel: 02-9390 6346 | Fax: 02-9390 6348 |
| Germany & All other countries | Oriental Motor (Europa) GmbH | Tel: +49-211-52067-00 | Fax: +49-211-52067-09 |