

Motor Selection

■ Belt/Leadscrew Application

■ Requirements

- Move Distance mm
- Time to Make Move s
- Maximum Linear Speed mm/s
- Push/Pull Force N

- Stopping Accuracy mm
- Work + Table Weight kg
- Angle °
- Distance per Pulse mm
- Stop Time s
- Screw Diameter mm
- Screw Length mm
- Screw Pitch mm/rev
- Screw Efficiency %
- Belt Weight kg

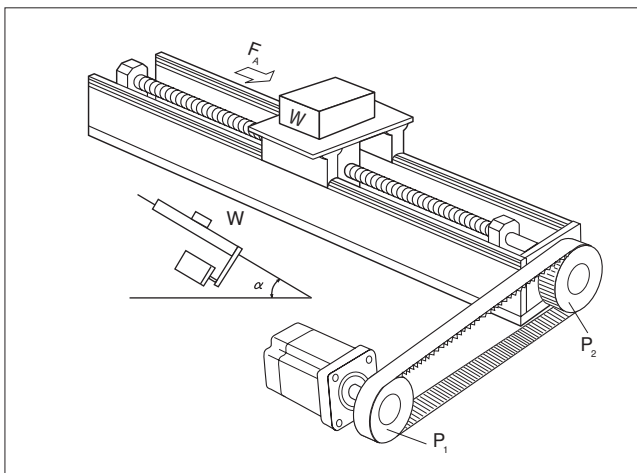

- Diameter of Motor Pulley mm
- Weight of Motor Pulley kg
- Diameter of Screw Pulley mm
- Weight of Screw Pulley kg

■ Alternate Motion Profile

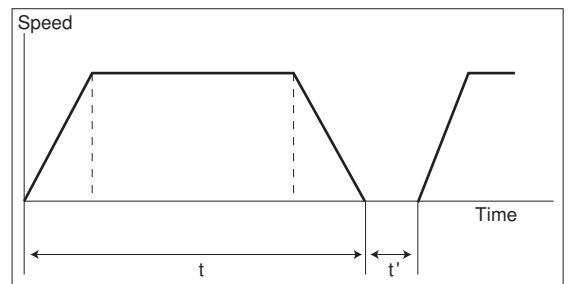

■ Customer Information

Date: _____

Company: _____	Application: _____
Name: _____	_____
Address: _____	_____
_____	_____
Tel: _____	_____
Fax: _____	_____

■ Contact:

- | | | | |
|-------------------------------|------------------------------|-----------------------|-----------------------|
| U.K. | Oriental Motor (UK) LTD | Tel: 01256-347090 | Fax: 01256-347099 |
| France | Oriental Motor (France) SARL | Tel: 01 47 86 97 50 | Fax: 01 47 82 45 16 |
| Italy | Oriental Motor Italia s.r.l. | Tel: 02-9390 6346 | Fax: 02-9390 6348 |
| Germany & All other countries | Oriental Motor (Europa) GmbH | Tel: +49-211-52067-00 | Fax: +49-211-52067-09 |